

tunnel luminaire

Holophane offers a road tunnel luminaire with a durable aluminium body sealed to IP66. Different lamp types and wattages ranging from 70w to 400w provides the flexibility to suit a wide variety of tunnel applications. The luminaire shown is a standard product, however, due to the specialist nature of tunnel applications, special versions are generally required. Therefore, please contact Holophane for further information and advice.

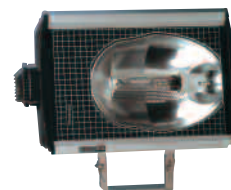



PRQ features and benefits

- Extruded aluminium body
 - > Durability
- Toughened glass cover
 - > Robust
- Silicone gasket
 - > Sealed against moisture
- Wide range of lamp wattages
 - > Suitable for a multitude of applications
- Twin lamp version
 - > Greater flexibility
- Galvanised steel mounting stirrup
 - > Flexibility in aiming angles

lamp types not included

PRQ-104:
70 - 250W high pressure sodium

PRQ-404:
150 - 400W high pressure sodium

PRQ-2404:
2 x 250W high pressure sodium

IP rating

IP66

approvals

Complies with EN60598



windage

Code

PRQ-104	0.196m ²
PRQ-404	0.228m ²
PRQ-2404	Available on request

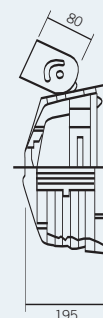
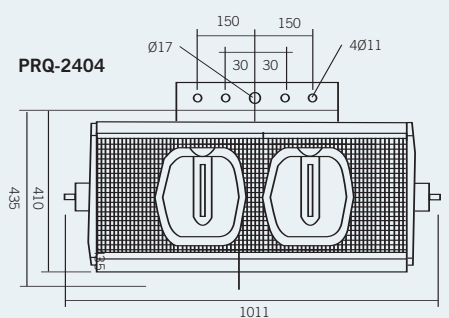
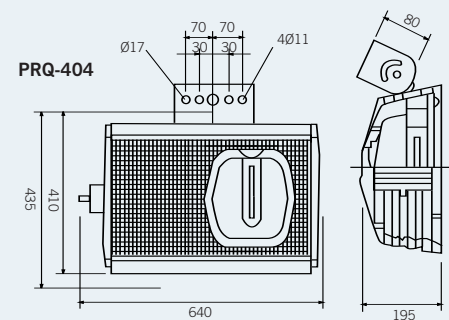
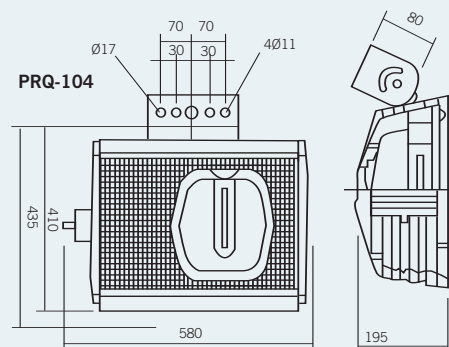



miracles are impossible

V
D
EAVUS

A la recherche d
A r
A nez est hyp
19
C'est un a

Merci à tous
Appel 05 16 28 47 2

WCL

PERMAOUP

